

CEILING SPEAKER

CS-3-6W

General Specification	
Type	CS-3-6W
Frequency Response	100-20KHZ
Sensitivity(1m/w)	91dB
Power Handling	6W
Power Taps	3W/6W
Line Input	100V
Hole For Mounting	Φ80
Dimension(D*H)	Φ135*80mm

Physical Specification	
Material	Iron
Component	4"
Finished Color	White
Unit Weight	0.65kgs
Gross Weight	13Kg/18pcs
Packing Dimension	64*32*27mm

Speaker Specification	
Voice Coil Size	0.12*2layer
DC Impedance	6.8Ω
Former	Kaptom
Magnet	Ferrite (197g) Φ70*32*10 (Y30)
Basket	Iron
Cone Material	Paper
Spider	Cloth
Dust Cap	Myler

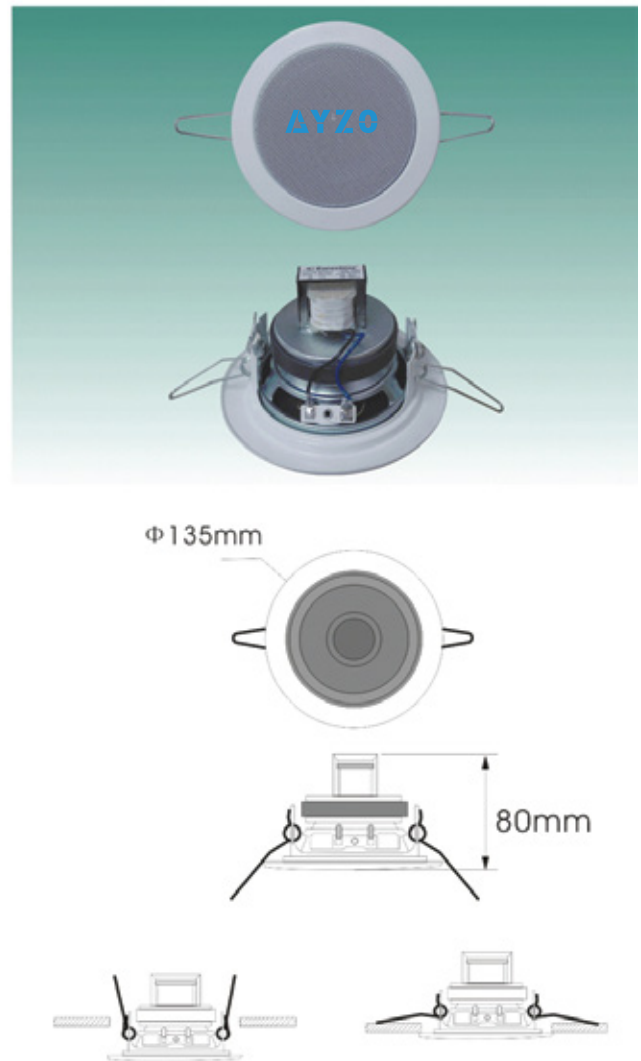



AYZO

SECURING BUSINESS SECURING LIVES

CEILING SPEAKER CS-3-6W

